

GENERAL

ALIADP The DCS Series is a diaphragm seal product combining APT80CS / APT90CS / APT90CSL transmitter, which designed for the high-viscosity / granular / high-temp. / high-corrosivity situation. DCS series diaphragm seal assembles Alia pressure / DP transmitter to form direct-mount / capillary-connections style.

FEATURES

- ❑ The maximum temperature comes up to 280 °C
- ❑ Multiple connection modes - Flange style / Tri-Clamp style
- ❑ Multiple diaphragms / alternative connection material
- ❑ Vegetable oil can be used for fill fluid for food industry
- ❑ Extreme hot and cold temperature
- ❑ Stainless Steel with PPC coating capillary
- ❑ IDF Tri-Clamp or union screw connection for food industry
- ❑ Oil-free treatment & water-free treatment
- ❑ Fast and dynamic response
- ❑ Improved performance, increased accuracy and great stability

STANDARD SPECIFICATION

- Process Fluid : Liquid, Gas, Vapor
- Application : Liquid Level, Differential Pressure, Gauge Pressure, Absolute Pressure
- Material
 - Flange : Carbon steel
 - : Stainless Steel 304
 - : Stainless Steel 316
 - Diaphragms : Stainless Steel 316L
 - : Hastelloy B / Hastelloy C
 - : Tantalum
 - : PTFE-coated Tantalum Diaphragm
 - Extended Tube : Stainless Steel 316
 - Capillary : Stainless Steel with PVC coating
- Flange Size : 40 mm, 50 mm, 80 mm, 100 mm
- : 1-1/2", 2", 3", 4"
- Process Connection : Flange
- Flange Rating : JIS 10K / JIS 20K / JIS 40K
- : ANSI 150# / ANSI 300# / ANSI 600#
- : DIN PN10 / PN16 / PN25 / PN40
- : Tri Clamp (DIN32676 / ISO2852)
- Extension Length : 2", 3", 4"
- Accuracy : +/-0.075% of Span
- Stability : +/-0.15% of URL for 2 years



- Installation Style
 - Direct-mount : APT80CS only
 - One-sided Capillary : APT80CS / APT90CS / APT90CSL
 - Two-sided Capillaries : APT90CS only
- Capillary Length : 1.0-10 m
- Max. Temperature
 - Direct-Mount : -20~130 °C
 - Remote Diaphragm : -40~280 °C
- Max. Pressure : 8.0 MPa
- Fill Fluid and Maximum Temperature
 - Silicone Oil (Max. Temperature 130 °C)
 - HT Silicone Oil (Max. Temperature 280 °C)
 - Fluorine Oil (Max. Temperature 160 °C)
 - Vegetable Oil (Max. Temperature 130 °C)
- Ambient Temperature : +/-0.18%~+/-0.5% of span per 20 °C
- Time Response : Less than 1.12 seconds
- Options
 - Water-free Treatment : Wetted parts are water-free treated in manufacturing
 - Oil-free Treatment : Wetted parts are oil-free treated in manufacturing



MEASURING RANGE & MAX. STATIC PRESSURE

Direct-Mount Diaphragm	Min. Range	Max. Range	Min. Range	Max. Range	Max. Static Pressure
Pressure Transmitter APT80CS with DCSD Series	0-10 kPa	0-100 MPa	0-1019.7 mmH ₂ O	0-10197 mH ₂ O	100 MPa
	0-100 mbar	0-1000 bar	0-40.15 inH ₂ O	0-401463 inH ₂ O	
	0-1.45 psi	0-14504 psi	0-0.1 kgf/cm ²	0-1020 kgf/cm ²	
Remote Diaphragm Seal	Min. Range	Max. Range	Min. Range	Max. Range	Max. Static Pressure
Pressure Transmitter APT80CS with DCS1 Series	0-6.0 kPa	0-8.0 MPa	0-611.82 mmH ₂ O	0-815.76 mH ₂ O	8.0 MPa
	0-60 mbar	0-80 bar	0-24.088 inH ₂ O	0-32117 inH ₂ O	
	0-0.87 psi	0-1160.3 psi	0-0.061 kgf/cm ²	0-81.578 kgf/cm ²	
Differential Pressure Transmitter APT90CS with DCS1 / DCS2 Series	0-6.0 kPa	0-8.0 MPa	0-611.82 mmH ₂ O	0-815.76 mH ₂ O	8.0 MPa
	0-60 mbar	0-80 bar	0-24.088 inH ₂ O	0-32117 inH ₂ O	
	0-0.87 psi	0-1160.3 psi	0-0.061 kgf/cm ²	0-81.578 kgf/cm ²	
Level Transmitter APT90CSL with DCS1 Series	0-6.0 kPa	0-8.0 MPa	0-611.82 mmH ₂ O	0-815.76 mH ₂ O	8.0 MPa
	0-60 mbar	0-80 bar	0-24.088 inH ₂ O	0-32117 inH ₂ O	
	0-0.87 psi	0-1160.3 psi	0-0.061 kgf/cm ²	0-81.578 kgf/cm ²	

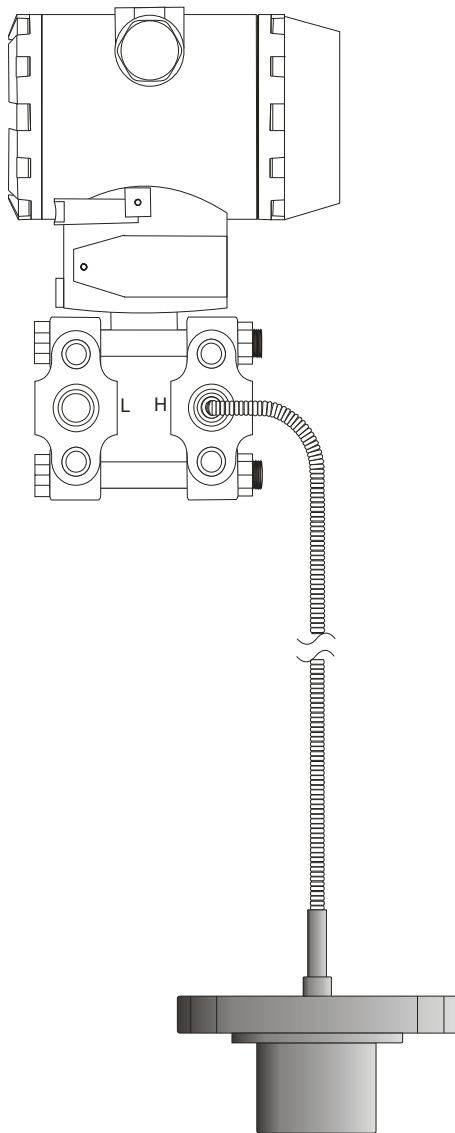

APT90CS with DCS1 Series

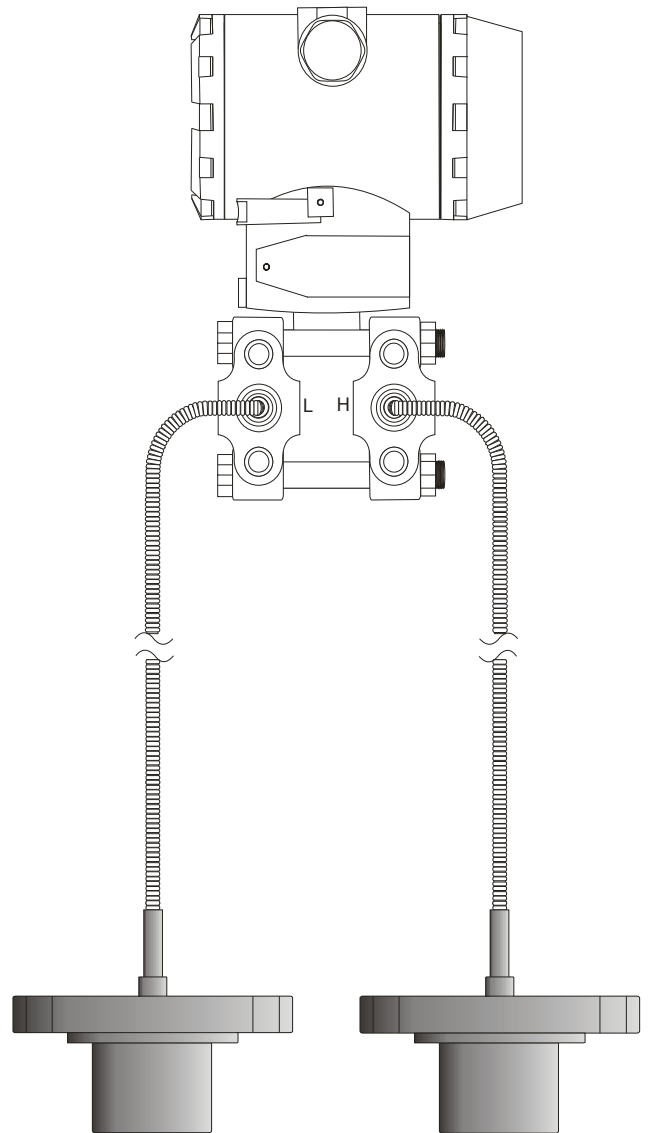

APT90CS with DCS2 Series

➤ DIMENSIONS

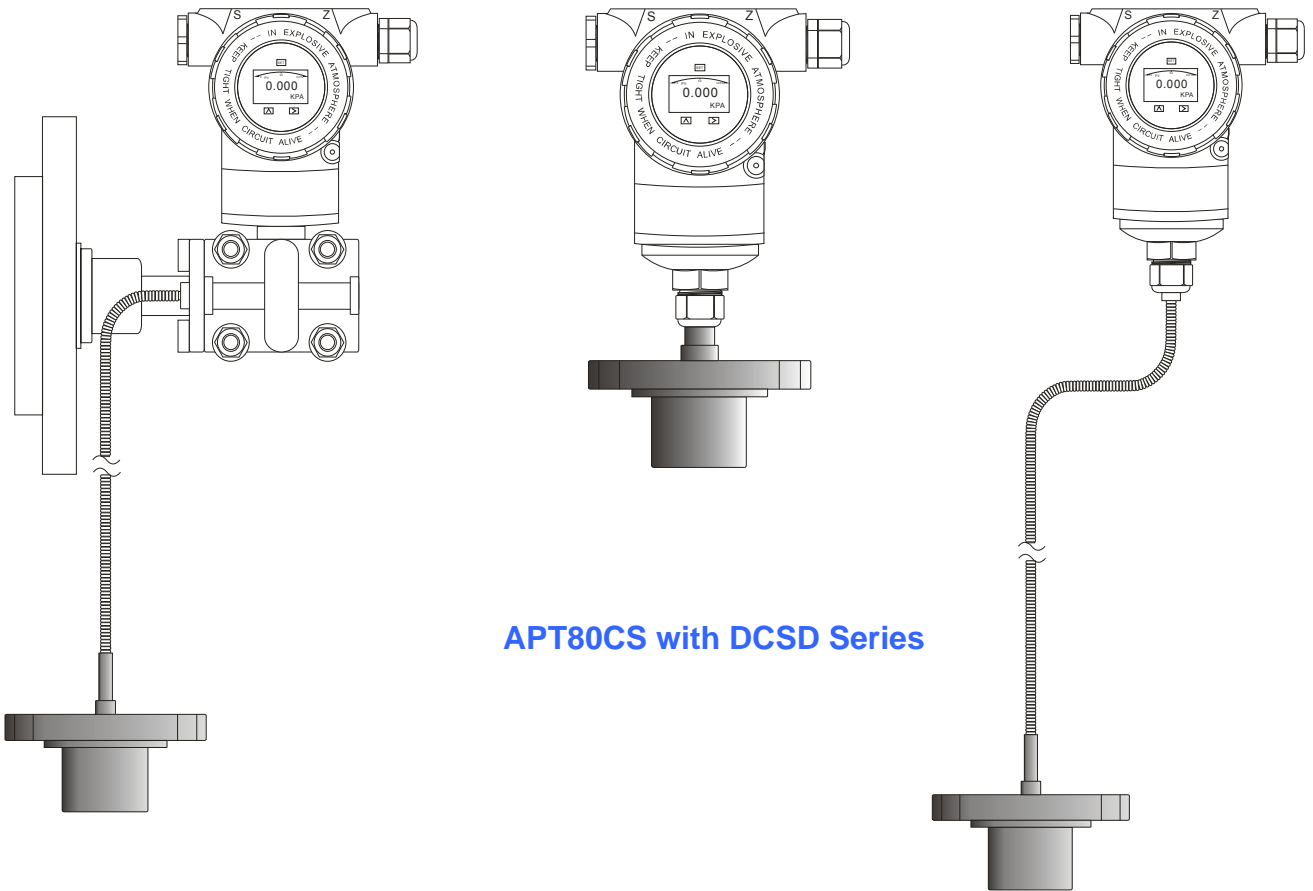

APT80CS with DCSD Series

APT90CSL with DCS1 Series

APT80CS with DCS1 Series

➤ FLANGE TABLES

Flange Style	Dimension of Flange			Bolt		Flange Style	Dimension of Flange			Bolt	
	C	D	T	H	NO		C	D	T	H	NO
1-1/2" JIS 10K	105	140	16	19	4	DN40 PN10	110	150	18	18	4
2" JIS 10K	120	155	16	19	4	DN50 PN10	125	165	20	18	4
3" JIS 10K	150	185	18	19	8	DN80 PN10	160	200	24	18	8
4" JIS 10K	175	210	18	19	8	DN100 PN10	180	220	20	18	8
1-1/2" JIS 20K	105	140	16	19	4	DN40 PN16	110	150	18	18	4
2" JIS 20K	120	155	16	19	4	DN50 PN16	125	165	20	18	4
3" JIS 20K	160	200	20	23	8	DN80 PN16	160	200	24	18	8
4" JIS 20K	185	225	22	23	8	DN100 PN16	180	220	24	18	8
1-1/2" JIS 40K	120	160	24	23	4	DN40 PN25	110	150	18	18	4
2" JIS 40K	130	165	26	19	8	DN50 PN25	125	165	20	18	4
3" JIS 40K	170	210	32	23	8	DN80 PN25	160	200	24	18	8
4" JIS 40K	205	250	36	25	8	DN100 PN25	190	235	24	22	8
1-1/2" ANSI 150#	98.6	127	18	15.7	4	DN40 PN40	110	150	22	18	4
2" ANSI 150#	120.7	152.4	19	19.1	4	DN50 PN40	125	165	24	18	4
3" ANSI 150#	152.4	190.5	24	19.1	4	DN80 PN40	160	200	24	18	8
4" ANSI 150#	190.5	228.6	24	19.1	8	DN100 PN40	190	235	24	22	8
1-1/2" ANSI 300#	114.3	155.4	24.6	22.4	4						
2" ANSI 300#	127	165.1	26.4	19.1	8						
3" ANSI 300#	168.1	209.6	32.4	22.4	8						
4" ANSI 300#	200.2	254	35.8	22.4	8						

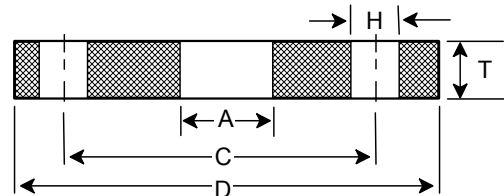

Model SELECTION GUIDE

DCS Series											
Example: DCS2-A22B4-N05-W											
DCS	X-	X	X	X	X	X	-X	XX	-X	Description	
Installation Style	D-										Direct-mount (APT80CS only)
	1-										One-sided Capillary Connects Remote Diaphragm Seal
	2-										Two-sided Capillaries Connect Remote Diaphragm Seal (APT90CS only)
Process Connection	1										PN10
	2										PN16
	3										PN25
	4										PN40
	A										ANSI 150#
	B										ANSI 300#
	J										JIS 10K
	K										JIS 20K
	L										JIS 40K
	T										Tri-clamp (DIN32676 / ISO2852)
Z										Other	
Flange Size	1										1-1/2" (Diaphragm Diameter If Extended: 38 mm)
	2										2" (Diaphragm Diameter If Extended: 48 mm)
	3										3" (Diaphragm Diameter If Extended: 66 mm)
	4										4" (Diaphragm Diameter If Extended: 89 mm)
Extended Diaphragm Length	0										Flush Diaphragm
	2										2" (50 mm) _ Extended Tube Material: S.S. 316
	4										4" (100 mm) _ Extended Tube Material: S.S. 316
	6										6" (150 mm) _ Extended Tube Material: S.S. 316
Diaphragm Material	N										Stainless Steel 316L
	B										Hastelloy B
	C										Hastelloy C
	T										Tantalum
	P										PTFE-coated Tantalum Diaphragm (PTFE Thickness: 40 µm) * Note
	Z										Other
Flange Material	N										Carbon Steel
	4										Stainless Steel 304
	6										Stainless Steel 316
	Z										Other
Fill Fluid	-N										Silicone Oil (Max. Temperature 130 °C)
	-S										HT Silicone Oil (Max. Temperature 280 °C)
	-F										Fluorine Oil (Max. Temperature 160 °C)
	-V										Vegetable Oil (Max. Temperature 130 °C)
Capillary Length	NN										Direct-Mount
	01-10										1-10 m
Option	-N										None
	-W										Oil-free and Water-free Treatment

Note: Wetted parts are coated with PTFE.